

HERBOLD



The new Herbold Pulverizer Type PU 650

The new Herbold Pulverizer PU 650 has a vertically placed drive and horizontal grinding tools - the ideal pulverizer for high performances.

Advantages of this series:

- Solid and fracture-proof welded steel construction
- Direct drive, no belt wear and tear, no additional transverse forces on the bearings
- Standard bearing temperature control, early detection of damages to the bearings, automatic switch off of the pulverizer
- Each disc manufactured in one single piece, thus ensuring an exact grinding gap adjustment and smaller grinding gaps; considerably fewer rejected oversized particles
- Patented special discs for special applications
- Easy change of tools due to the horizontal configuration of the grinding chamber
- High throughput rates
- Compact, space-saving design
- Discs with considerably higher re-sharpening volume, up to 20 regrinds possible – thus significantly lower operating costs
- The PU 650 can be equipped with motors from 75 to 110 kW

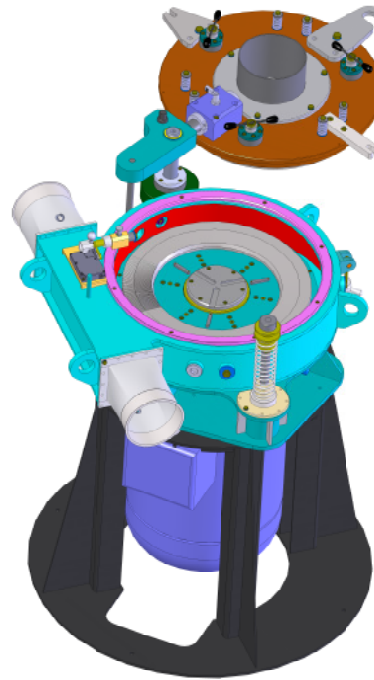

Examples for throughput capacities:

Rigid PVC	approx. 800 micron	1000 – 1500 kg/h
HIPS	approx. 800 micron	700 – 1100 kg/h
HDPE	approx. 800 micron	1000 – 1400 kg/h
PC	approx. 800 micron	700 – 1000 kg/h
ABS	approx. 800 micron	400 – 680 kg/h

Capacities depend on the quality and size of infeed material and on the condition of the pulverising tools as well as on the motorisation.

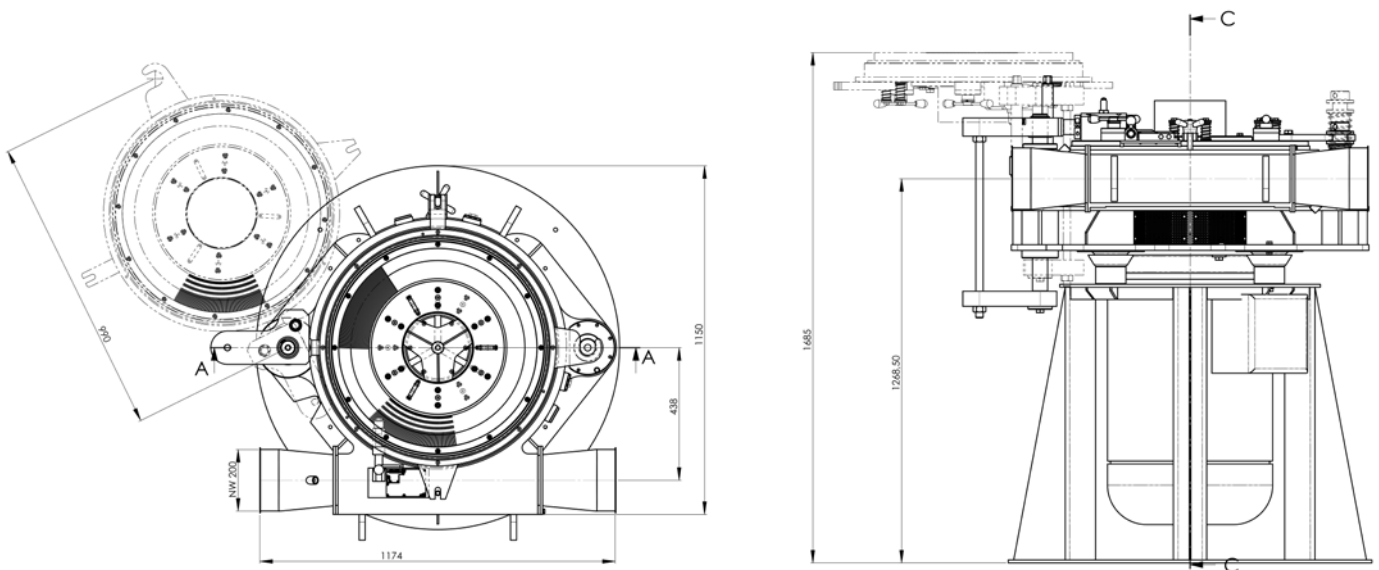

Our Product Range

- Guillotines
- Shredders
- Hammer mills
- Granulators
- Pulverizing systems
- Washing systems & components
- Plastcompactors/agglomerators

Herbold Meckesheim GmbH

Industriestr. 33
74909 Meckesheim
Postfach 1218
74908 Meckesheim
Deutschland
Tel.: + 49 (0) 6226/932-0
Fax: + 49 (0) 6226/932-495
E-Mail: herbold@herbold.com
Internet: www.herbold.com

Our subsidiary:

Herbold Meckesheim USA Resource Recycling Systems Inc.

130 Industrial Drive
North Smithfield, RI 02896, USA
P.O. Box 239
Slatersville, RI 02876, USA
Tel.: +1 401 597/5500
Toll-free (US/CDN): +1 888/612 RRSI (7774)
Fax: +1 401 597/5535
E-Mail: info@herboldusa.com
Internet: www.herboldusa.com