

Herbold HOG-Shredder Series HGM



The New Series: Low Speed HOG-Shredders

- HERBOLD Meckesheim GmbH has developed a new series of low-speed HOG-shredders, expanding their product range:

HGM series, available in two sizes

- **HGM 60/100** and **HGM 60/145**

User-friendly HOG-shredders

Advantages of the HGM series

- Insensitive to foreign bodies due to an integrated shear pin coupling
- Smooth running due to the massive full-steel rotor and the V-belt drive
- Longer knife life
- Most inexpensive knife design
- Armour-plated housing
- Excellent access to the rotor and the cutting knives due to a horizontally divided housing
- Low-speed operation, less fines, dust and noise

Functional mode:

The Herbold-HOG shredder of the HGM series is a single-rotor size-reduction machine. It presents the combination of a granulator and shredder combining the advantages of both:

advantages - granulator:

- equipped with knives
- size-reduces by cutting
- has a screen
(suited for small screen hole sizes!)

advantages - shredder:

- relatively insensitive to foreign bodies
- cuts with a large cutting angle
- operates at reduced speed

The HOG-shredder of the HGM series has been designed heavier than conventional granulators and shredders; rotor can be changed within 90 minutes.

HERBOLD

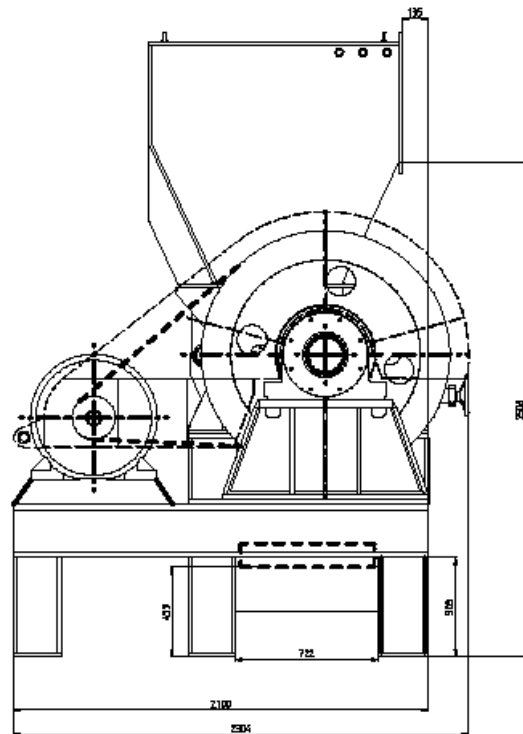

Design:

The HOG-shredder is equipped with a heavy-duty full-steel rotor with a short segmented knife in a helical pattern.

The inside of the machine is supplied with bolted wear-plates.

The centrally divided housing which is hydraulically operated simplifies the access to the cutting chamber for cleaning and maintenance.

The screen cradle is located in the bottom section of the housing. Hydraulics are used to raise and lower the screen cradle secured by a clamping device.

Application range:

HOG-shredders of the HGM series have been developed for the reduction of difficult, especially tough material or material containing tramp material.

application examples:

- pre-sized reduced tires
- bottles from household waste
- metal-reinforced rubber or plastic parts
- shredded waste from car recycling

The HOG-shredder has been protected against damage due to the entry of massive foreign bodies by means of an overload coupling; this coupling will disengage and the machine will stop, before any severe damages to the rotor or the housing occur.

Different types of the HGM series

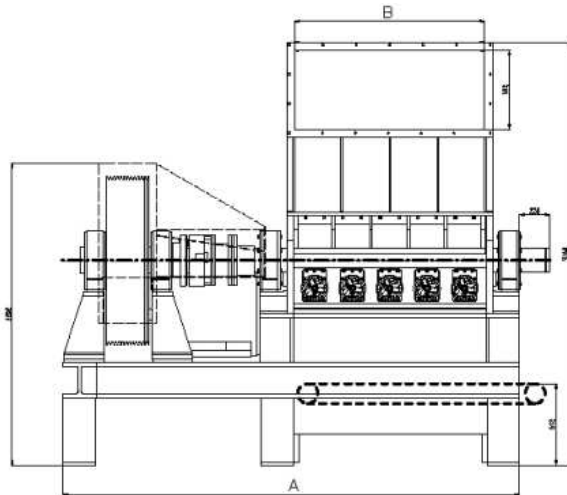

View into the cutting chamber of a HOG-shredder, series HGM

Type	A in mm	B in mm
HGM 60/100	3010	1020
HGM 60/145	3410	1420



Technical Data

Type	HGM 60/100	HGM 60/145
Feed opening	approx. 630 x 1050	approx. 630 x 1420
Rotor shape	V3	V3
Rotor knives (175 mm long)	18	24
Stator knives (175 mm long)	6 x 2	8 x 2
Rotational speed in rpm	200	200
Drive power in kW	75	90
Drive type	V-belt	V-belt
Overload protection	shear pin coupling	shear pin coupling
Armoured housing	standard	standard
Hydraulic swivelling of the screen support	standard	standard
Hydraulic opening of the housing	standard	standard
Number of screens	2	2
Weight	approx. 18 tons	approx. 24 tons
<u>Options:</u>		
Stator-knife block with a 3rd row of knives	on request	on request
Gear transmission	on request	on request

Edition: 12/2002 - Specifications are not binding and subject to change without notice.

Rotor knives:

Knives are made of tool steel; knife holders with interchangeable inserts may be mounted in the knife insertion pouches on the rotor. Depending on the use of the machine the knives can repeatedly be resharpened (with normal material) or - after turning them once - have to be replaced (with very fine material).

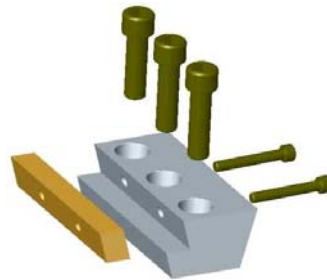

minimized costs for cutting tools due to cassette knives

Stator knives:

In the lower section of the housing 2 rows of stator knives have been mounted. The front of the housing's upper section can be exchanged; a holding fixture for additional stator knives may be fitted here, if required by the intended use of the machine.

The stator knives are mounted in adjustable knife holders: Before changing the knives these stator knife holders are equipped with the knives and adjusted in an adjustment jig outside the machine. So, after mounting the holders in the machine no further adjustments will be required and still a relatively precise cutting gap will be ensured.

Our product range

- Granulators
- Pulverizers
- Shredders
- Hammer mills
- Guillotines
- Washing lines
- Plastcompactors

Herbold Meckesheim USA
Resource Recycling Systems, Inc.

333 George Washington Highway
Smithfield, Rhode Island 02917

Phone: 401-232-3354
Toll-Free: 888-612-7774
Fax: 401-3223-5425

E-Mail: info@herboldusa.net
Internet: www.herboldusa.net

Herbold Meckesheim GmbH

Industriestrasse 33
D-74909 Meckesheim /
Germany

P.O. Box 1218
D-74908 Meckesheim /
Germany

Phone: +49 (0) 62 26 / 932-0
Fax: +49 (0) 62 26 / 932-495

E-Mail: Herbold@Herbold.com

Internet: www.Herbold.com