

Pre-Washing Tank

The function of the prewashing tank is based on the swim-sink principle, i.e. on the different specific weights of the various components contained in the feed material that will either cause them to float on the water surface or to sink to the bottom of the tank. Thus the device serves for separating the light and heavy components of the waste material that is being fed into it. A washing/discharge drum (item A) installed on top of the tank cleans the floating fraction of the feed material by constantly dipping it underneath the water surface and at the same time discharges the material to the follow-up unit (e.g. a granulator within the recycling line).

The heavier fractions (stones, glass, metals, etc.) of the feed material sediment is inside the conical bottom part (item B) of the tank. This waste fraction of the feed material will be discharged into the dewatering container beneath the tank by means of a rake conveyor (item C). This unit helps to prevent severe damages to the granulator by rising the overall lifetime of the granulator.

The material needs to be shredded before going into the pre-washing tank. Typically the contaminated material that is to be shredded needs to be as follows:

For hard plastics size reduction of approximately 50 mm, up to 3 tons/hour

For film, 200 mm, up to 1.5 tons/hour

Functioning:

Feeding of the material into the feeding hopper of the foreign body separator where beneath an inclined conveying screw is placed, transporting the good material from a chamber filled with water.

In the front area of the foreign body separator, foreign bodies are separated from the good material. By injecting water into the chamber, the good material is conveyed upwards and sinking foreign bodies (stones, metals, glass, etc.) are evacuated by the timed double-valve combination from the foreign body separator and discharged into customer's container.

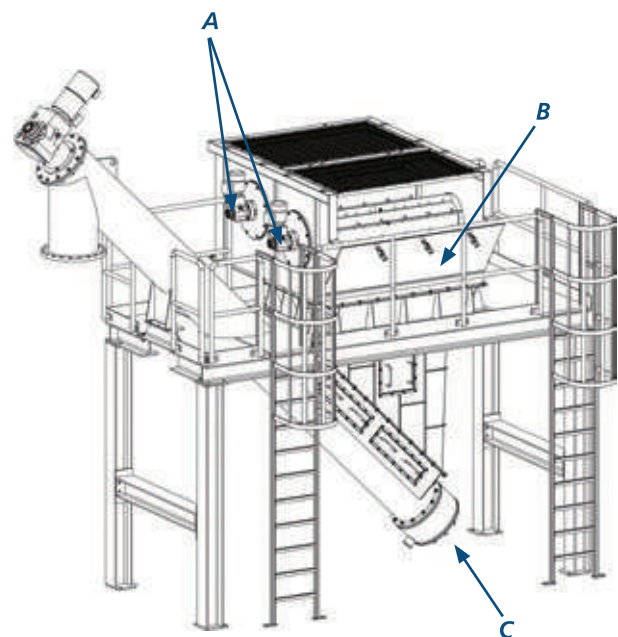

Technical data:

Model	SA 180/200
Tank: (mm)	1800 x 2200
Conveyor drive: (kW)	2 x 0,55
Discharge drive: (kW)	2,2
Discharge device: (kW)	3
Maintenance platform:	
Product touching parts galvanized; stainless steel as an option.	

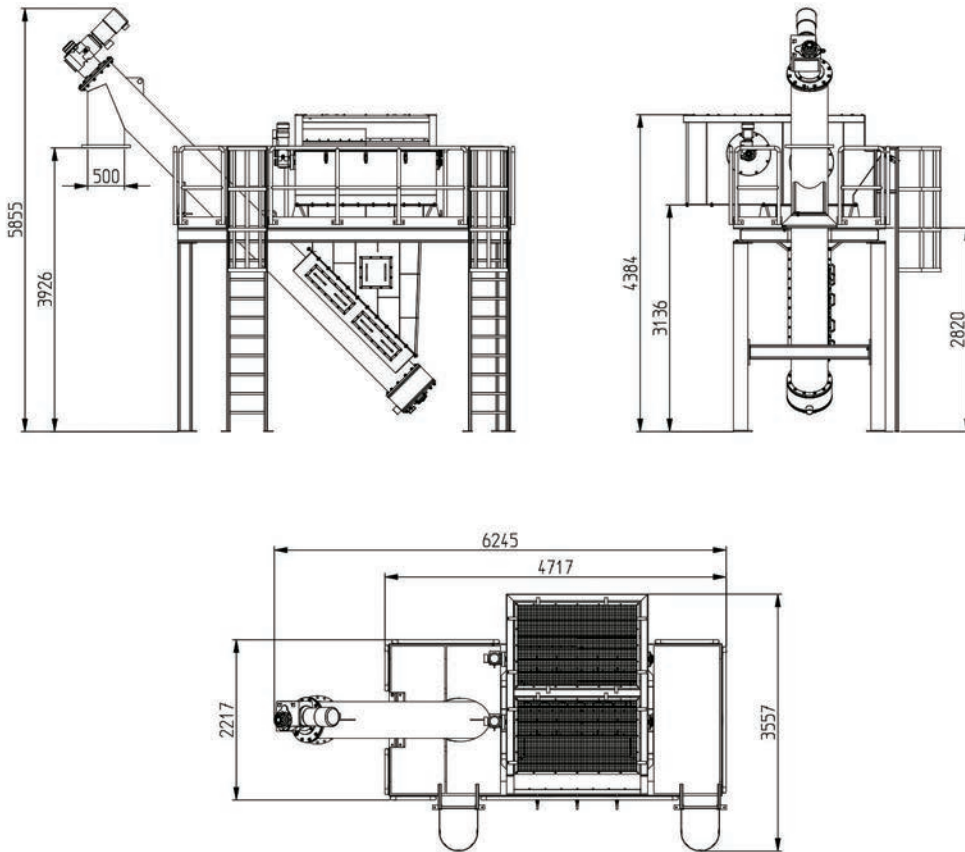

Our Product Range

Size Reduction

- › Shredder
- › Granulators
- › Pulverizing Systems

Washing / Separation Systems & Components

- › Pre-washing Units
- › Friction Washers
- › Separation Tanks and Hydrocyclones
- › Mechanical and Thermal Drying
- › Water Processing

Agglomeration

- › Plastcompactors

Service

- › Parts and Overhauls
- › Inspections and Trouble Shooting
- › Upgrades and Performance Service

HERBOLD Meckesheim GmbH

Industriestr. 33 • 74909 Meckesheim • Fon: + 49 (0) 6226 / 932-0 • Mail: HERBOLD@HERBOLD.com • Web: www.HERBOLD.com

Specifications are not binding and subject to change without notice. 10 / 2019